



isoweld® Stress Plates for induction welding attachment

Application

- TPO and PVC/KEE/TPA membrane attachment using isoweld® induction welding tools



Features and Benefits

- Proprietary adhesive for secure weld
- Stacked for ease of use
- 22 ga. G90 Galvanized steel

Product Selection

| Material No. | Item | Description | Carton Wt. (lbs.) | Carton Qty. |
|--------------|--------------------|-----------------|-------------------|-------------|
| 1555270 | isoweld® PVC plate | FI-P-6,8-PVC-PC | 34 | 500 |
| 1555269 | isoweld® TPO plate | FI-P-6,8-TPO-PC | 34 | 500 |

Specifications and CAD Drawing: FI-P-6.8-TPO-PC-RevIR / FI-6.8-PVC-PC-RevIR

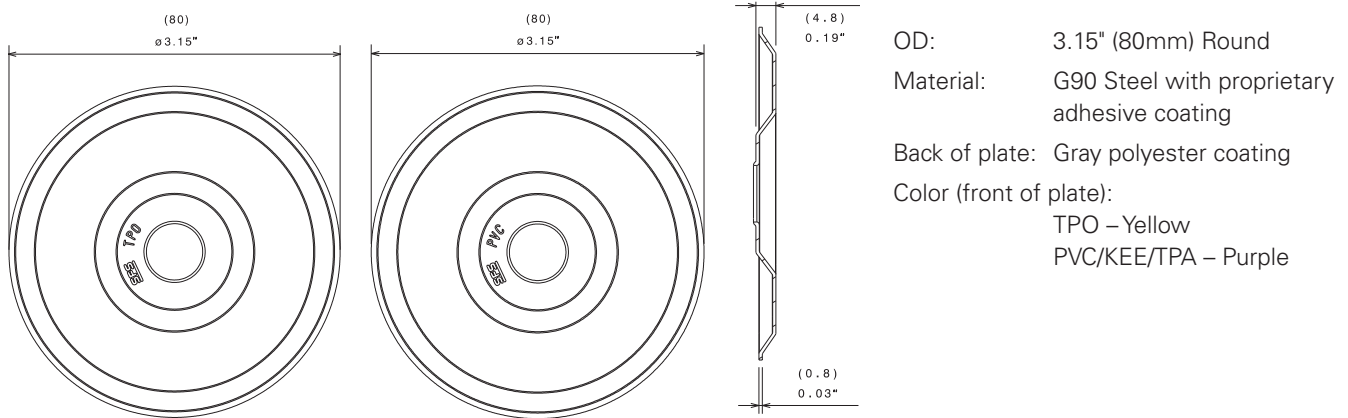

Approvals



State of Florida: FL20311

16-0712.08

Installation and Application Considerations

Use with isoweld® induction welding tools and applications approved by the roofing system manufacturer. Use with:

- #15 Dekfast
- #12 Purlin
- TPR-L Peel Rivet

Contact SFS for special application use with #12 or #14 Dekfast

Metric values are approximate conversions.

The details stated are results of tests and/or calculations and therefore are non-binding and do not represent guaranties or warranted characteristics for not specified applications. All calculations therefore have to be checked and approved by the responsible planner ahead of execution. The user is responsible to assure compliance with all applicable laws and regulations.

